

Part Numbers: Use the model number of the tank followed by the index number for the item in question to determine the part number – i.e. FDS-2010A-4 Air Motor.

Items 43, 45A (bolt for item 45), 47, 50 and 51 are available as an option in stainless steel – to order stainless steel version, add suffix “SS” to part number.

Certain items are not exactly as shown and/or are only available as part of a kit.

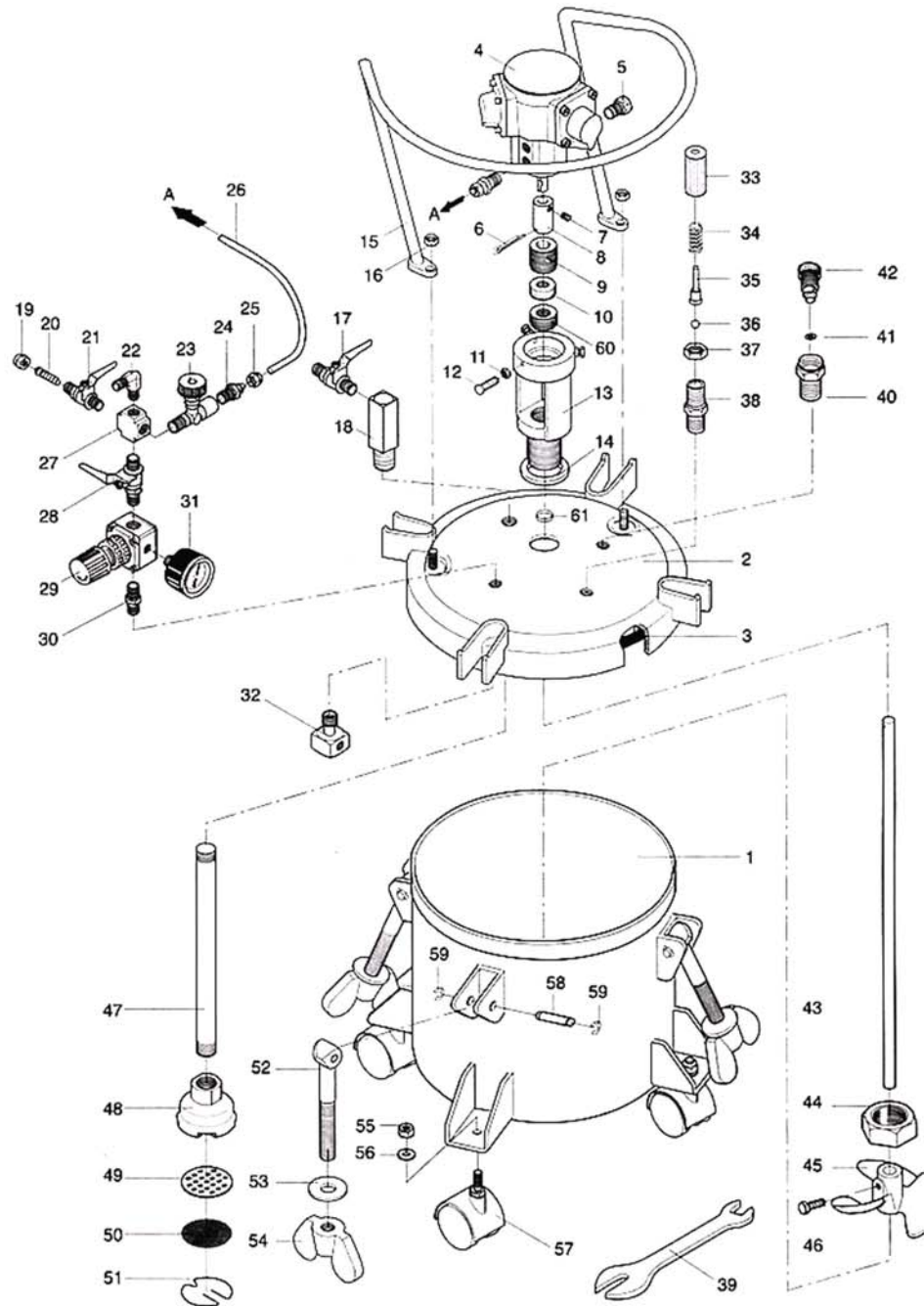

GENERAL INTRODUCTION (AIR AGITATION)

This pressure air tank is equipped with an air motor, air pressure regulator, safety valve, material outlet, inner material tank and 4 casters. All the component parts are made with the finest materials and were strictly inspected before assembling. The surface of the tank has been treated with durable paint.

The material being sprayed can be agitated automatically by the air motor. This keeps the material smooth during spraying and prevents any colour differences caused by material settling. The tank capacity enables the operator to carry out almost any job with professional results. Enamel paint, chemical liquid, glue, fluid food, sticky material etc. can also be sprayed as smoothly as required.

PRECAUTIONS

Thoroughly clean the tank after each use. This will reduce the necessity for spare parts and also reduce wear and tear on the paint tank.

WARNING

1. Pressurize the paint tank to a maximum load of 80 PSI.
2. The safety relief valve is designed to protect the tank from over pressurizing. The original valve is set at 60 PSI. Do NOT adjust unless necessary.
3. Do not modify the tank by drilling, welding or machining the tank in any way. Doing so may result in poor performance, may weaken the tank and will void any applicable warranty.

OPERATING INSTRUCTIONS

Check and make sure there is no pressurized air in the tank before using. If there is, release it by turning the relief valve clock wise until the pressure is released.

1. Loosen all wing nuts and swing bolts, and remove the lid assembly.
2. Pour the material to be sprayed into the material tank.
3. Replace the lid assembly and tighten the tank securely. Note: The wing nuts must be tightened on the cover very tightly and in sequence (up - down left to right and so on.) in a similar way that you would tighten lug nuts on a car. The nuts must NOT be tightened one at a time in rotation.
4. Connect the air supply hose to the air inlet. Note: To prevent material contamination, an air filter is recommended.
5. Connect the atomizing air hose to the air outlet.
6. Connect the material hose to the fluid outlet.
7. Turn on the air supply, then turn the air pressure regulator clock-wise until proper working pressure is achieved. Do not adjust to more than 80 PSI.
8. Open the air outlet valve.
9. Open the fluid outlet valve.
10. Adjust atomizing air by means of the gun.
11. Operate your spray gun according to the manufacturer's directions.

CLEANING AND MAINTENANCE

Thoroughly clean tank after each use.

1. Close the air inlet valve
2. Open the material inlet valve.
3. Release all the pressure inside the tank.
4. Loosen all wing nuts and swing bolts, and remove the lid assembly.
5. Empty the material tank. Use the appropriate solvent/water to clean the inside of tank plus all parts which have come in contact with the material being sprayed.
6. Pour clean solvent/water into the tank.
7. Replace the lid assembly and tighten the tank securely. Note: The wing nuts must be tightened on the cover very tightly and in sequence (up - down left to right and so on.) The nuts must NOT be tightened one at a time in rotation.
8. Open the air inlet valve.
9. Operate the spray gun until clean solvent is atomized.
10. Repeat steps 1 through 9.
11. Empty solvent.

TROUBLE SHOOTING GUIDE

PROBLEM	CAUSE	REMEDY
Air pressure gauge is not working	Gauge is broken or damaged	Replace gauge
Material settles during operation	Material not agitated enough Agitation propeller loose Air motor not working properly	Increase agitation. Inspect & tighten propeller if necessary. Inspect & replace motor if necessary
Material or air leaking out from lid	Worn gasket. Wing nuts not tightened enough.	Replace gasket. Tighten wing nuts in sequence (up - down left to right and so on)
Air leaking from release lock	O-ring may be damaged	Replace as necessary
Material does not atomize properly	Filter or fluid may be clogged	Inspect and clean filter and fluid tube as necessary

Note: Check pressure gauge occasionally. The indicator should be at zero whenever there is no pressure in the tank.